

EUROCAST

INDUSTRIES

Machine Shop



DOOSAN VTR1216M Vertical lathe with options :

- turning
- milling
- drilling
- tapping

- Recommended turning DIA for detail: 1250mm
- Max Turning DIA for detail 1600mm
- Max turning height for detail 1250mm
- Detail weight up to 2000 kg
- Optimal production batches : 5 - 50 off/batch

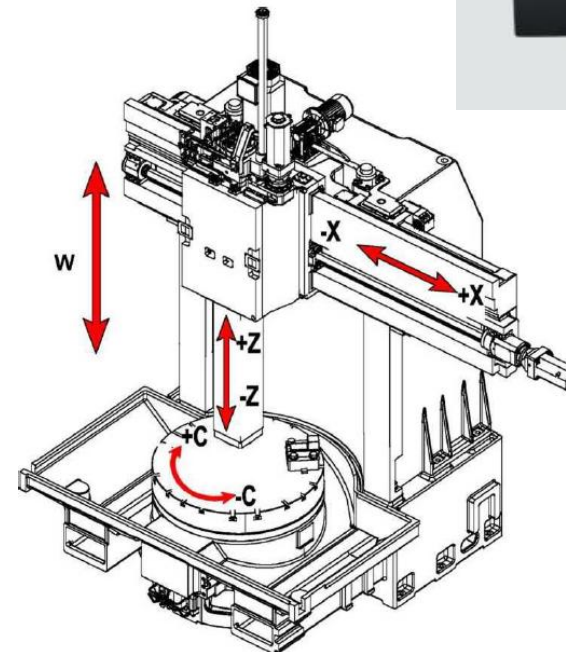

Lathe DOOSAN GT2600M with option:

- turning
- milling
- drilling
- tapping

- Recommended turning DIA for detail : 250mm
- Max Turning DIA for detail : 320mm
- Max turning height for detail : 610mm
- Detail weight up to 50 kg
- Optimal production batches : 50 - 300 off/batch

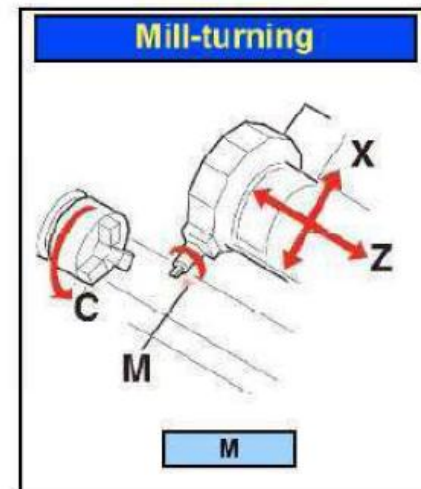

Horizontal Machining Center With Dual Table DOOSAN NHM8000-

- Machine table size : 800x800 mm
- Travel X/Y/Z: 1400/1050/1200 mm
- Working area on rotating table : DIA 1450mm
- Max.Height : 1550 mm
- Detail weight up to 2000 kg
- Optimal production batches : 50 – 300 off/batch



2x High Speed Machining Center With Dual Table DOOSAN VC430

- Machine table size : 1180x712mm (2x Palet size 712x475mm)
- Travel X/Y/Z: 560/430/570 mm
- Detail weight up to 100 kg
- Optimal production batches : 100 – 1000 off/batch

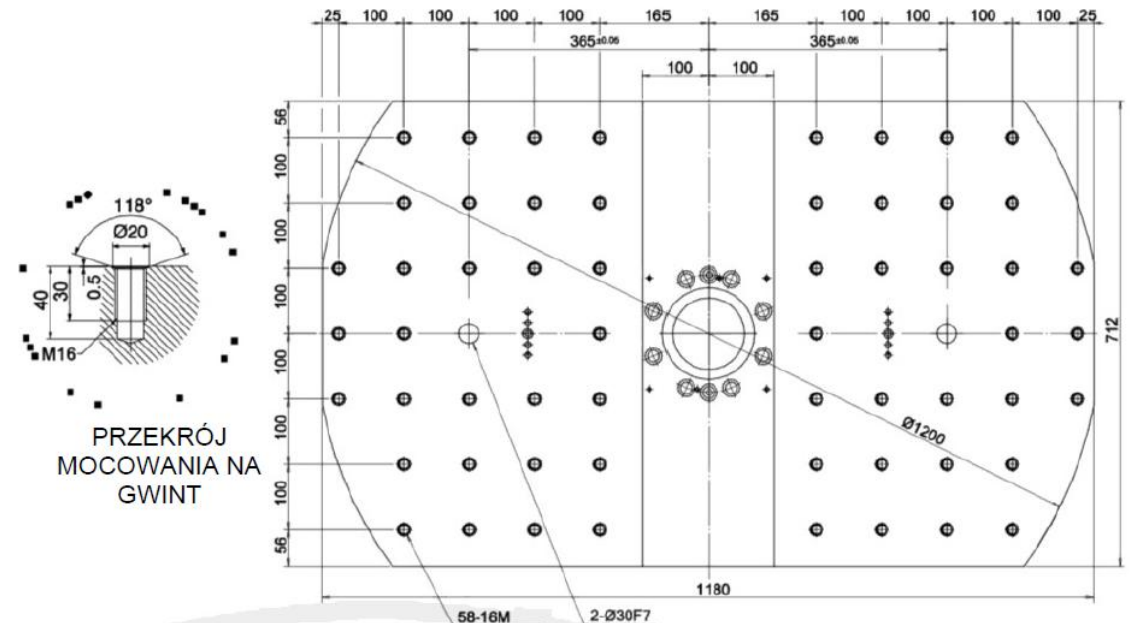
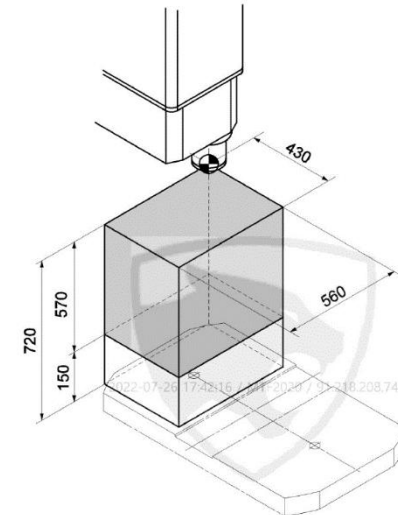

Faro Arm Quantum E with 3D scanner Faroblu XP



CMM LK ALTERA measuring range 1500x2000x1000

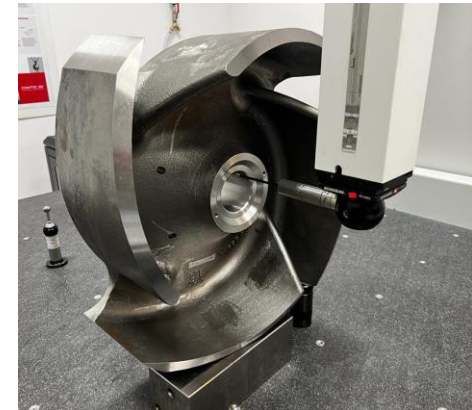

Pressure Testing

We are experts in production of pressure retaining castings, therefore a significant part of our production is being pressure tested to ensure castings are leak free

Working medium:

- air
- water (mixture water and oil)
- oil

Impregnation of castings can be carried out on request

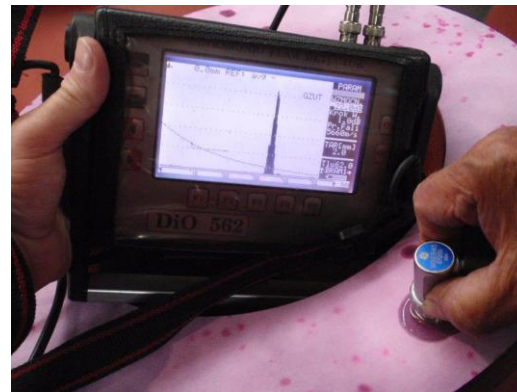
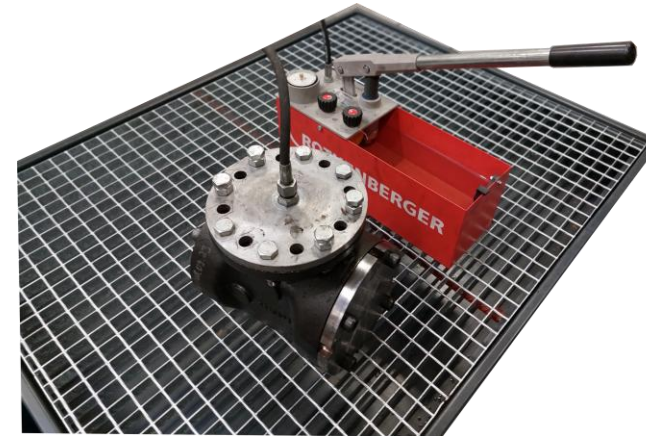

NDT

- Ultrasonic Testing (UT)
- Magnetic Particle Inspection (MPI)
- X-Ray examination (RTG)
- Dye Penetrant Testing (PT)

Contact Person

Grzegorz Trzaska

Head of Enquiries Department

Mob.: +48 451 070 367

e-mail: gtrzaska@eurocast-ind.com

Radosław Żelazny

Supply and Business Development Senior Specialist

Mob.: +48 664 710 066

E-mail: rzelazny@eurocast-ind.com

Łukasz Wala

Supply and Business Development Specialist

Mob.: +48 500 069 185

e-mail: lwala@eurocast-ind.com

Thank You.